

A JOHN DEERE COMPANY



WIRTGEN GROUP

KLEEMANN

ORIGINAL WEAR PARTS

CLOSE TO OUR CUSTOMERS

TOP CLASS PRODUCTION

Know-how, innovation, quality.

For the past 100 years, KLEEMANN GmbH has been manufacturing innovative machines and plants for professional users in the natural stone and recycling industry. High levels of performance and innovative details, simple handling and maximum safety for the operator - this is what KLEEMANN crushing and screening plants stand for.

KLEEMANN offers a wide and varied range of parts and accessories. Choosing the right crushing tools, especially, significantly improves the result. The areas of application for mobile crushing and screening plants are very diverse. The wear parts are usually exposed to harsh conditions and high wear. Your goal is to increase durability and reduce operating costs. Use original KLEEMANN Parts to succeed in achieving these goals - we will be happy to advise you.

For further information, visit: parts.wirtgen-group.com



MAIN WEAR PARTS FOR THE MOBIREX MR 110(i)/130(i) EVO2

01 Conveyor belts

- > Conveyor belts
- > Conveyor belt rollers
- > Scraper
- > Drive-/return drum
- > Rubber seal

02 Post screen

- > Screen media
- > Rubber profiles
- > Wear plates screen box
- > Tension clamp
- > Clamping screws
- > Guide rail

03 Power unit

- > V-belts
- > Filter (oil, hydraulic, air, diesel)

04 Drive unit

- > Drive unit parts
- > Trackpads
- > Drive unit rollers

05 Impact crusher

- > Blow bars
- > Impact plates
- > Wear plates
- > Impact bar
- > Impact toggle
- > Rubber and chain curtain
- > Inlet chute
- > Pressure plate
- > Rotor

06 Pre-screen

- > Slotted grate
- > Perforated plate
- > Screen media
- > Blind cover
- > Wear plates side walls prescreen
- > Compression spring

07 Feed unit

- > Wear plates hopper
- > Wear plates feeder
- > Compression spring
- > Return chute/oversize chute



CRUSHING TECHNOLOGY

The right wear parts for the best results.

- 01** Rubber curtain
- 02** Chain curtain
- 03** Impact toggle
- 04** Wear plates
(see page 32)
- 05** Rotor
- 06** Impact plates
- 07** Blow bars
- 08** Impact bar



Crushing tools for impact crushers

Impact toggles

KLEEMANN only uses manganese high carbon steel for the impact toggles with excellent strain hardening for high wear resistance. The impact toggles ensure long service lives thanks to the thick-walled wear layer and perfect crushing results - thanks to their geometry.

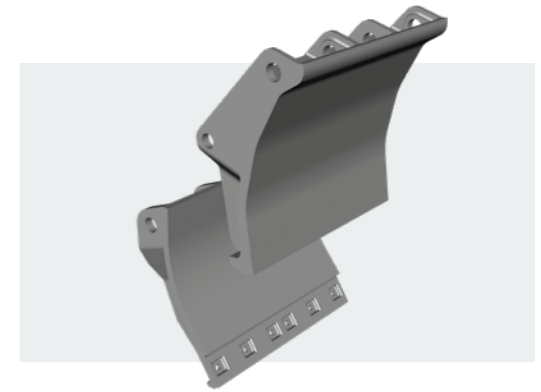

Impact bars

Original KLEEMANN impact bars are made of extremely wear-resistant material. The precise design of the plug connector guarantees quick changes during assembly.



Impact plates

The thick-walled impact plates made of KLEEMANN Resistant Steel protect the lower impact toggle against premature wear. Different qualities are available:



OVERVIEW OF IMPACT PLATES

Impact plate	Design	Properties	Application
Impactplate.Mn	Manganese	> high impact resistance > low risk of fracture	Recommended for > large feed size > high share of uncrushable material Inefficient with medium to high abrasiveness
Impactplate.M	Martensite	> high impact resistance > low risk of fracture > 1.5 times longer service life than Impact.Mn > good price-performance ratio	Recommended for > recycling rubble and concrete > natural stone with larger feed size Inefficient with high abrasiveness
Impactplate.MC	Martensite-ceramic	> high wear resistance through ceramic inlays	Recommended for > recycling of rubble and concrete with a small to medium share of iron and asphalt > natural stone with an abrasiveness of up to 600 g/t Inefficient with large feed sizes
Impactplate.C	Chromium	> 3 to 4 times longer service life compared to Impactplate.Mn > high level of wear resistance	Recommended for > secondary crushing stage with very abrasive natural stone or river gravel > crushing of asphalt with small feed size (< 400 mm with crushability < 30%) Inefficient in rubble recycling with a medium to high share of iron

TARGETED TO SUCCESS

For perfect crushing results.

An optimum crushing result is always achieved by means of the ideally matched components of the overall plant and the settings made by the operator.

With these tips, it is possible to find the ideal settings for any task.

Feed material

- > Feed size: Wherever possible, the maximum feed size should not exceed 80% of the specified crusher opening
- > Compressive strength: Mineral materials can be used with a maximum compressive strength of 100 MPa in the first crushing stage, 150 MPa in the second crushing stage
- > Mineral type: Impact crushers from the SHB series process soft to medium-hard natural stone, such as limestone, dolomite or sandstone, and are used for recycling mineral raw materials such as mixed rubble, bricks, asphalt and concrete.

Rotor speed and crushing gap

- > When the rotor speed is increased, the crushing curve shifts upwards, which results in an increase in the fines content in the end product.

An increase in speed usually results in a higher throughput. Only if the intake performance deteriorates due to the increased number of strokes will there be a reduction in throughput.

Crushing ratio

- > The maximum crushing ratio (ratio of feed grain size / grain output) largely depends on the physical properties of the feed material. This results in the following standard values:

CRUSHING RATIO STANDARD VALUES

Feed material	Compressive strength [MPa]	Circuit	Reduction ratio
Limestone, soft to medium-hard natural stone	<150	open	up to 10:1
		closed	
Recycling (rubble, asphalt, concrete)	<100	open	up to 15:1
		closed	
Reinforced concrete (depending on concrete quality and iron content)	< 100	open	up to 15:1
		closed	

Areas of application for impact crushing plants

NATURAL STONE

Coal / clay / marble / limestone	Sandstone, gritstone / greywacke	Gravel / granite	Basalt	Iron ore / gneiss / quartzite / diabase, gabbro
Asphalt / reinforced demolished concrete	Demolished concrete / mixed rubble		Blast furnace slag	Steel slag

RECYCLING



KLEEMANN > PROCESS KNOWLEDGE

MOBIREX - MR 110(i) EVO2 / MR 130(i) EVO2 crushing curve in open circuit (< 15% oversize grain)

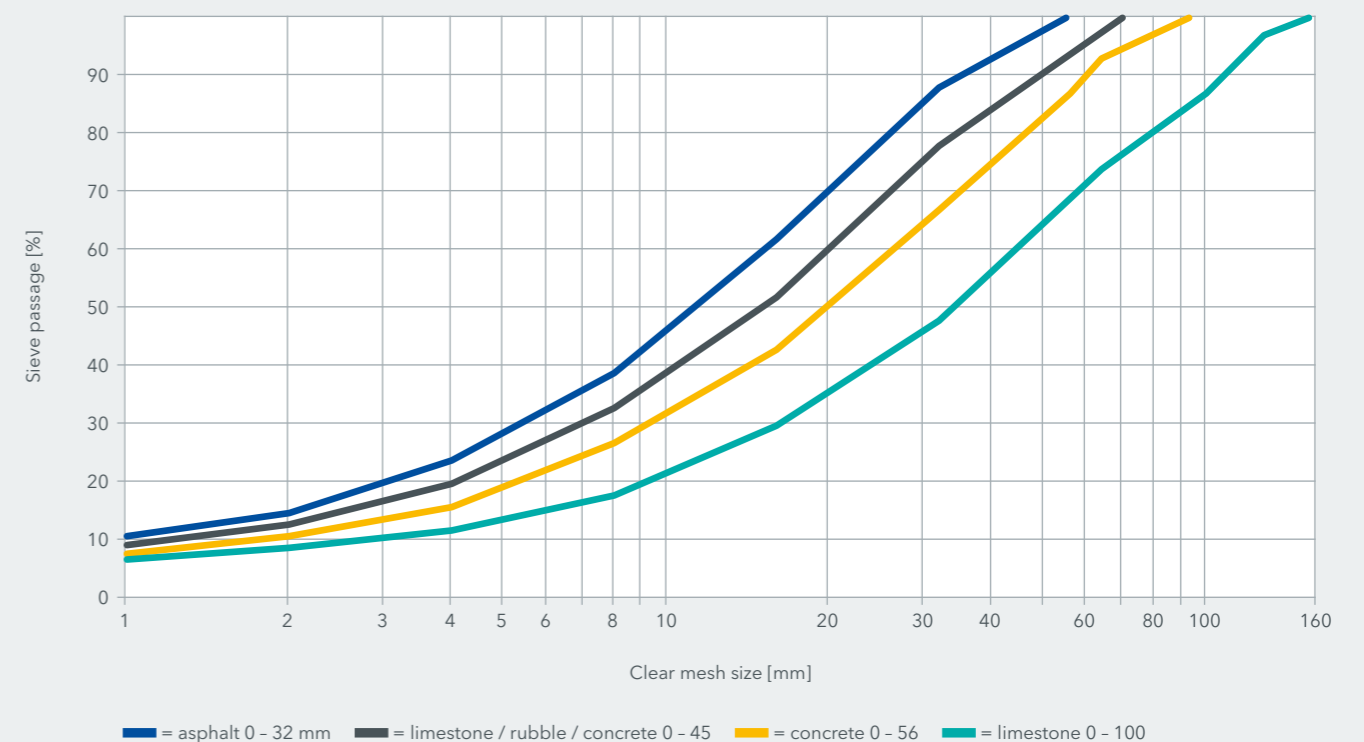

BLOW BARS

For less wear and optimum results.

The cost-effective use of rotor ledges is influenced by factors such as feed material, rotor speed, moisture content of the material, feed size and reduction ratio. Depending on the area of application and material properties, different rotor ledges are available to achieve the best possible results.

Important questions for selecting application-specific blow bars

- > What type of material is being crushed?
- > How can the feed size be classified?
- > What is the range of abrasiveness?
- > Does the material contain uncrushable elements?

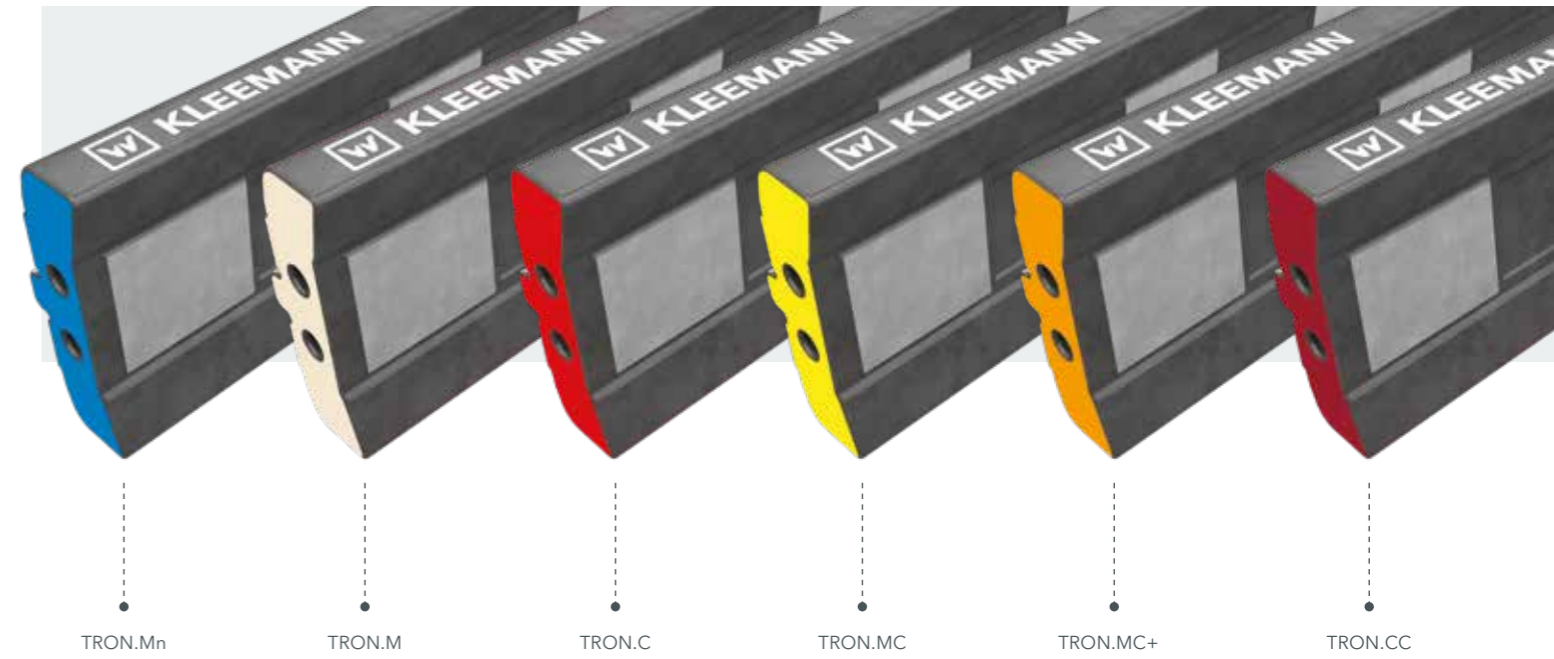

Different shapes are available:

There are three different shapes of blow bars for the KLEEMANN impact crusher series: C-Shape, X-Shape, S-Shape. These in turn are available in different materials and designs:

Monolithic blow bars

- > Manganese TRON.Mn
- > Martensite TRON.M
- > Chrome TRON.C

Composite blow bars with ceramic inlays

- > Martensite-ceramic TRON.MC, TRON.MC+
- > Chrome-ceramic TRON.CC

RECOMMENDED APPLICATIONS FOR BLOW BARS

Application	Low abrasiveness		Medium abrasiveness		High abrasiveness	
	Limestone processing	Small share of uncrushable elements	Reinforced concrete	Natural stone	Asphalt	Natural stone
Good	TRON.Mn (max. feed size: 600 mm)	TRON.C (max. feed size: 400 mm)	TRON.M (max. feed size: 700 mm)		TRON.C (max. feed size: 400 mm)	
Better	-	TRON.MC (max. feed size: 600 mm)			TRON.MC+ (max. feed size: 600 mm)	
Best	-	TRON.MC+ (max. feed size: 600 mm)			TRON.CC (max. feed size: 300 mm)	

MAIN WEAR PARTS FOR THE MOBICAT MC 110(i) EVO2

01 Conveyor belts

- > Conveyor belts
- > Conveyor belt rollers
- > Scraper
- > Drive-/return drum
- > Rubber seal

02 Power unit

- > V-belts
- > Filter (oil, hydraulic, air, diesel)

03 Drive unit

- > Drive unit parts
- > Trackpads
- > Drive unit rollers

04 Jaw crusher

- > Jaws
- > Side wedges
- > Clamping wedge
- > Cam
- > Deflector plate
- > Thrust Plate

05 Pre-screen

- > Slotted grates
- > Perforated plate
- > Screen media
- > Blind cover
- > Wear plates side walls prescreen
- > Compression spring

06 Feed unit

- > Wear plates hopper
- > Wear plates feeder
- > Compression spring



JAW CRUSHER CRUSHING TECHNOLOGY

The heart of the machine.



- 01** Optimised crusher geometry with long crusher jaw
- 02** Extensive selection of crusher jaws: Regular Teeth, Sharp Teeth, Flat Teeth, Multitype Teeth, Wavy Teeth
- 03** Side wedges for protecting the crusher housing (see page 33)
- 04** Deflector plate with replaceable wear plates

TARGETED TO SUCCESS

For perfect crushing results.

An optimum crushing result is always achieved by means of the ideally matched components of the overall plant and the settings made by the operator.

With these tips, it is possible to find the ideal settings for any task.

Feed material

- > Feed size: Wherever possible, the maximum feed size should not exceed 90% of the specified crusher opening
- > Compressive strength: Mineral materials can be used with a maximum compressive strength of 300 MPa *
- > Mineral type: All soft to hard natural stones, e.g. dolomite, granite, basalt, diabase, quartzite or gneiss as well as residual construction materials such as rubble, bricks and reinforced concrete

* Depending on the material and machine type, higher values are also possible

Crushing ratio

The maximum crushing ratio (ratio of feed grain size / grain output) largely depends on the physical properties of the feed material. This results in the following standard values:

- > 7:1 at < 100 MPa (recycling)
- > 5:1 at < 150 MPa (limestone)
- > 3-4:1 at < 300 MPa (hard stone)

Exceeding the crushing ratio leads to an undesirable decrease of the crushing capacity and to an increase in wear.



Areas of application for jaw crushing plants

NATURAL STONE

Limestone / sandstone, gritstone / greywacke / gravel / granite	Gneiss / marble / quartzite / diabase / gabbro / basalt	Iron ore	Coal	Clay
Demolished concrete / reinforced concrete / rubble	Asphalt	Blast furnace slag		Steel slag

RECYCLING

KLEEMANN > PROCESS KNOWLEDGE

MOBICAT MC 110(i) EVO2 crushing curve

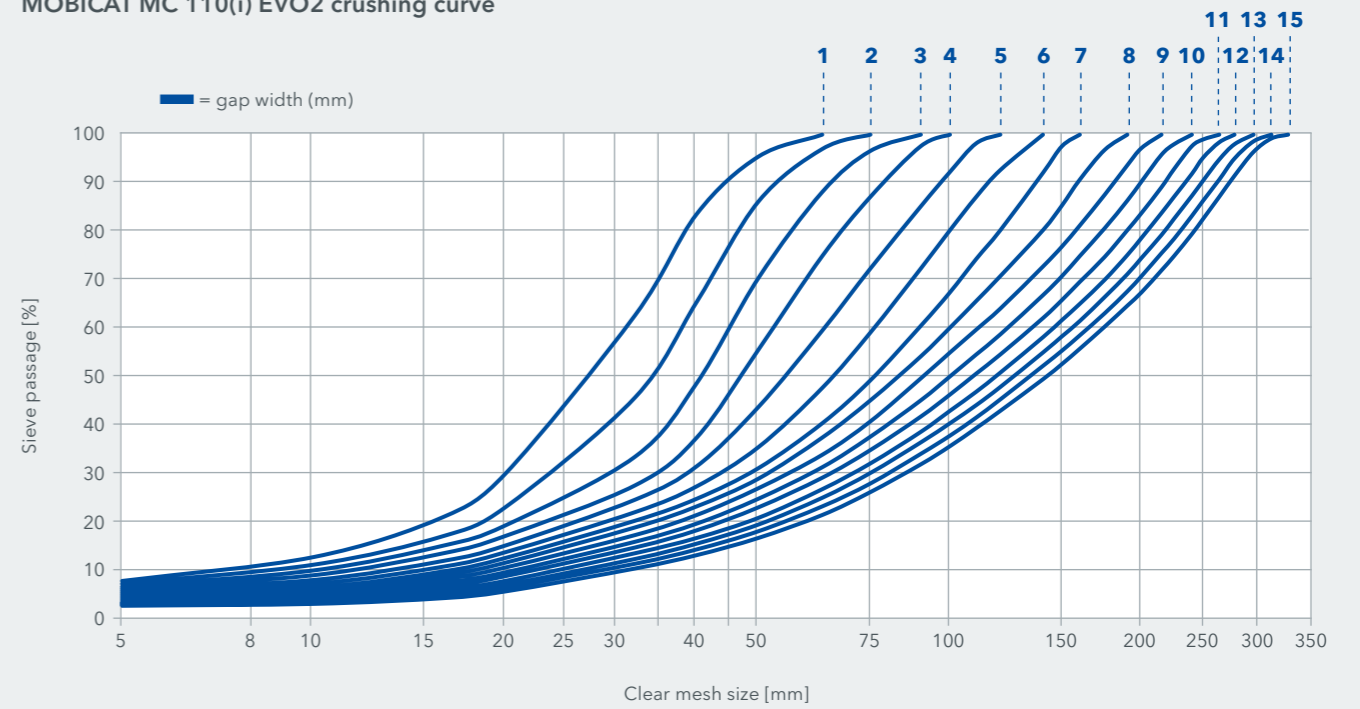

CSS (CLOSED SIDE SETTING)

- 01 40 mm 02 50 mm 03 60 mm 04 70 mm 05 80 mm 06 90 mm 07 100 mm 08 110 mm 09 120 mm 10 130 mm
- 11 140 mm 12 150 mm 13 160 mm 14 170 mm 15 180 mm

THE RIGHT CRUSHER JAW

For less wear and optimum results.

KLEEMANN offers a very wide range of parts and accessories. The selection of the correct crusher jaws, in particular, has a strong influence on the result: for example, different crusher jaws have to be used for abrasive rock than for coarse rock.

The crushing principle

The crushing material is crushed by the jaw crushers in the wedge-shaped pit between the fixed crusher jaw and the crusher jaw articulated on an eccentric shaft. The material is crushed by the elliptic course of movement and transported downwards by gravity. This occurs until the material is smaller than the set crushing gap.

Low-wear material

The crusher jaws installed in jaw crushers from KLEEMANN are made from a special manganese casting characterised by excellent durability of the basic body. Through the compressive load, during operation the manganese casting forms a highly wear-resistant surface for long service lives.

In ideal operation, the main wear occurs in the lower half of the crusher jaw. If the teeth are completely worn (smooth crusher jaw), the crusher jaw should be turned over or replaced. The crushing capacity (t/h) is reduced considerably when the crusher jaws are smooth because the material is mainly crushed and no longer broken. The machine requires more power to break, which results in unnecessarily increased operating costs, higher wear and poorer crushing results.

Timely replacement of worn crusher jaws improves the crushing results and also reduces operating costs considerably.

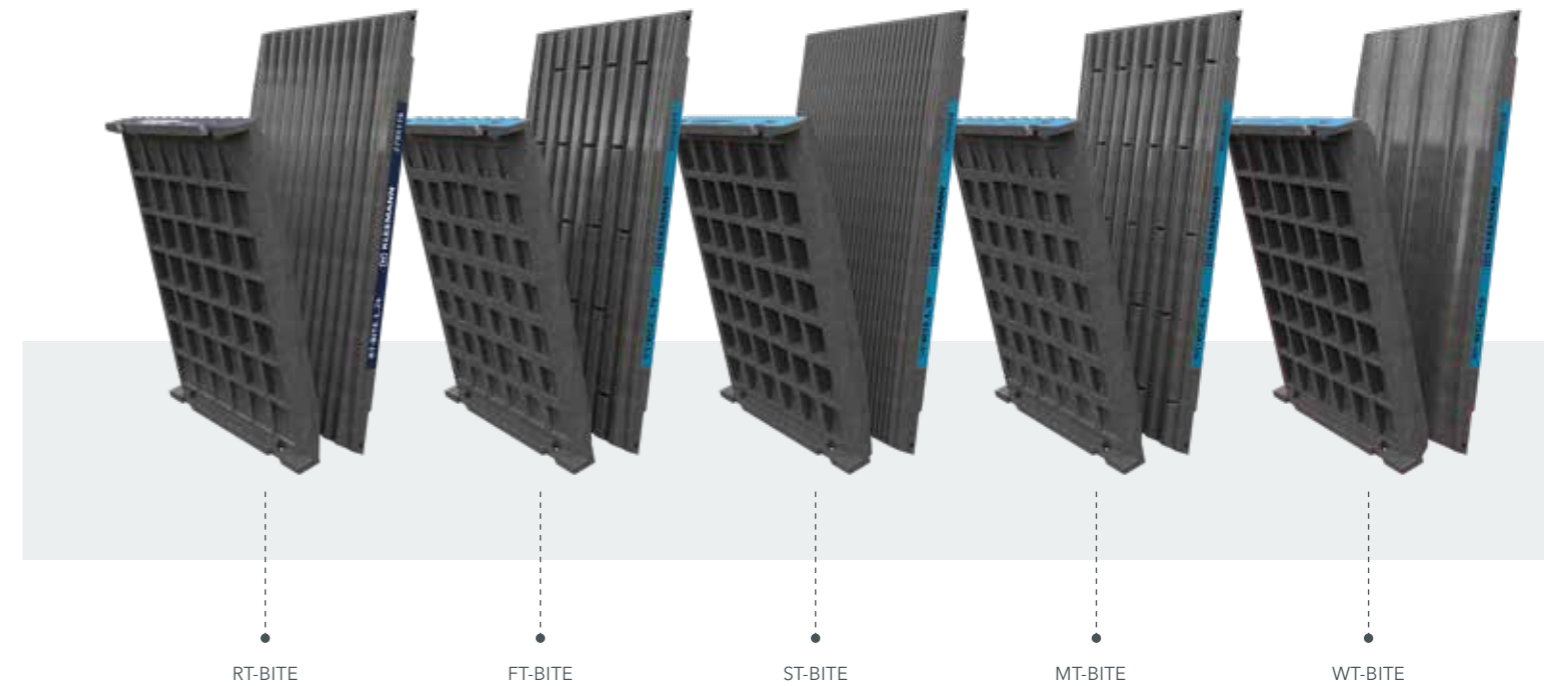

RECOMMENDED USE OF CRUSHER JAWS

Tooth shape	Final product grain size	Feed material					
		Hard stone	Soft and medium-hard rock	Gravel	Rubble/ Recycling	Laminated medium-hard rock	Recycling cohesive material
RT-BITE (regular-teeth)	> 60 mm	●	●●	●●	●●	●●	●
FT-BITE (flat-teeth)	> 60 mm	●●	●	●	●	●	●
ST-BITE (sharp-teeth)	< 60 mm	●	●	●●	●	●●	●
MT-BITE (multitype-teeth)	> 60 mm	●●	●	●	●	●	●
WT-BITE (wavy-teeth)		●	●	●	●	●	●●

●● Highly recommended ● Recommended ● Not recommended

KLEEMANN > PROCESS KNOWLEDGE

Optimised results through correct loading:

- > The optimum fill height of the jaw crusher up to the bevelling of the crusher jaws should not be exceeded
- > Continuous overfilling leads to premature wear, reduced service life of bearings and damage to the prescreen
- > Continuous underfilling leads to uneven wear, a poor grain shape and reduced plant performance
- > The maximum feed size of 90% of the feed opening should be observed
- > The CSS should always be correctly set

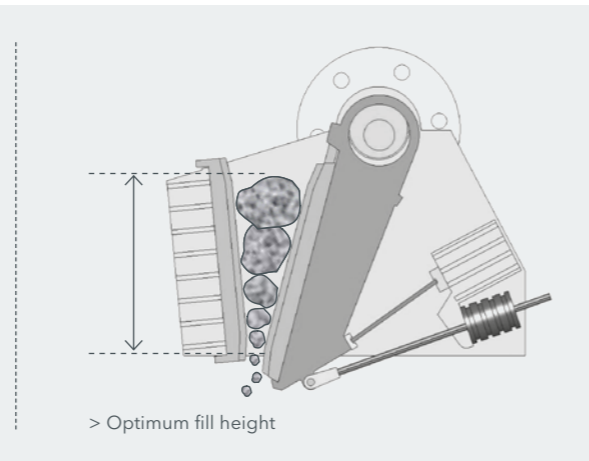

Crushing tools for jaw crushers





Original crusher jaws

Depending on the application field and material properties, various crusher jaws are available to achieve optimum results.



RT-BITE TOOTH SHAPE - REGULAR-TEETH

- > Suitable for recycling, natural stone and gravel
- > Large spaces between teeth to facilitate the discharge of fine or already crushed material
- > Ideally balanced properties with regard to service life, energy requirements and crushing pressure
- > Reduces flaky shares in the crushed material
- > RT-BITE.20 & RT-BITE.24 for abrasive natural stone

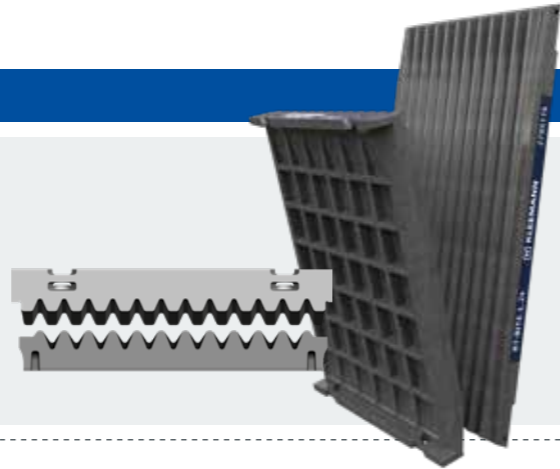

FT-BITE TOOTH SHAPE - FLAT TEETH

- > Suitable for natural stone
- > Flat teeth work efficiently in abrasive material (higher wear dimensions)
- > Particularly efficient in abrasive material thanks to higher wear dimensions
- > Small clearance for fines (screening required)
- > Higher share of flaky crushed material

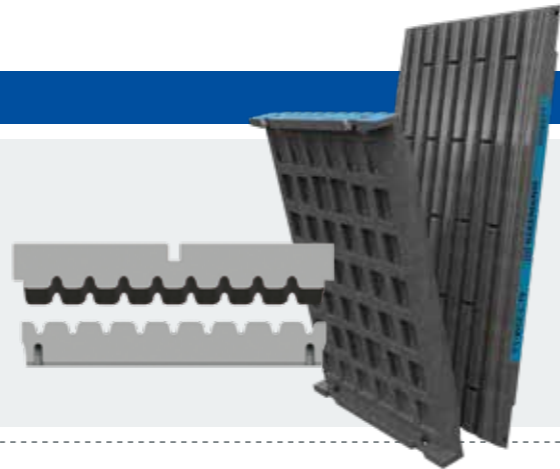

WT-BITE TOOTH SHAPE - WAVY TEETH (RECYCLING)

- > Caking and clogging reduce the output of the jaw crusher
- > Special corrugated tooth profile for recycling
- > Optimised geometry of the rear walls for improved draw-in angle inside the crushing chamber
- > Reduces or prevents adhesion of sticky material

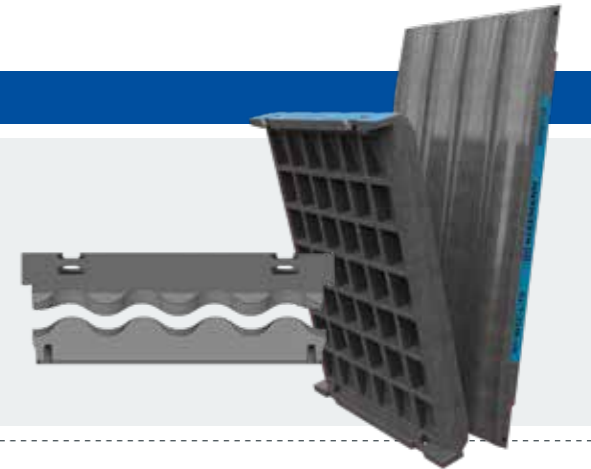

ST-BITE TOOTH SHAPE - SHARP TEETH

- > Suitable for producing grit
- > Good grip on material thanks to sharp tooth profile
- > Recommended with small gap widths (< 60 mm)

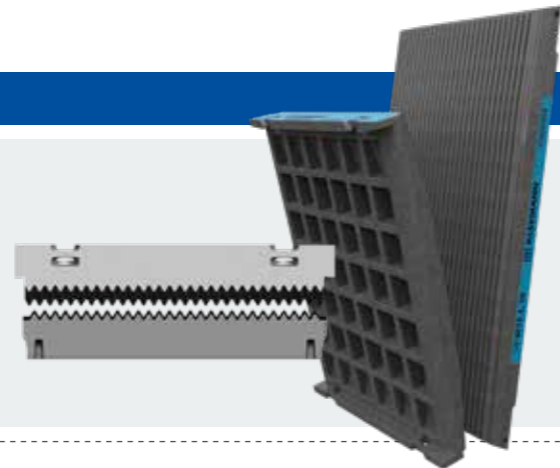

MT-BITE TOOTH SHAPE - MULTITYPE TEETH

- > Specially designed for hard stone applications
- > Tooth profile positioned between RT-BITE & FT-BITE
- > Sharp toothing with larger spaces between teeth
- > Reduced crushing forces due to reduced crusher load
- > Lower fuel requirements
- > Improved discharge of fine/crushed material

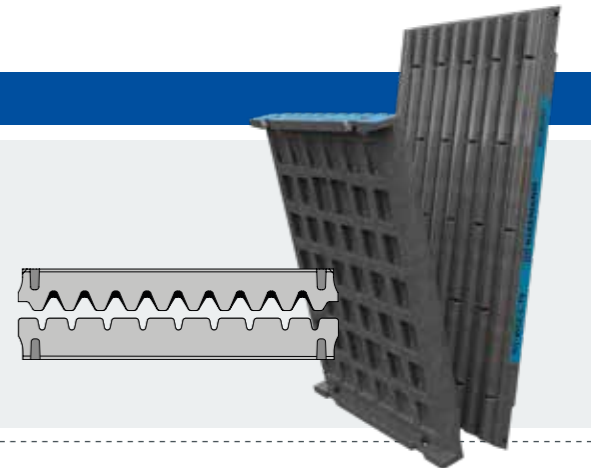

MAIN WEAR PARTS FOR THE MOBICONE MCO 90(i) EVO2

01 Conveyor belts

- > Conveyor belts
- > Conveyor belt rollers
- > Scraper
- > Drive-/return drum
- > Rubber seal

02 Post screen

- > Screen media
- > Rubber profiles
- > Wear plates screen box
- > Tension clamp
- > Clamping screws
- > Guide sheet

03 Drive unit

- > Drive unit parts
- > Trackpads
- > Drive unit rollers

04 Power unit

- > V-belts
- > Filter (oil, hydraulic, air, diesel)

05 Cone crusher

- > Bowl liner
- > Mantle liner
- > Wear parts crusher
- > Service package

06 Feed unit

- > Wear plates hopper
- > Return chute/oversize chute
- > Impact beam



CONE CRUSHER CRUSHING TECHNOLOGY

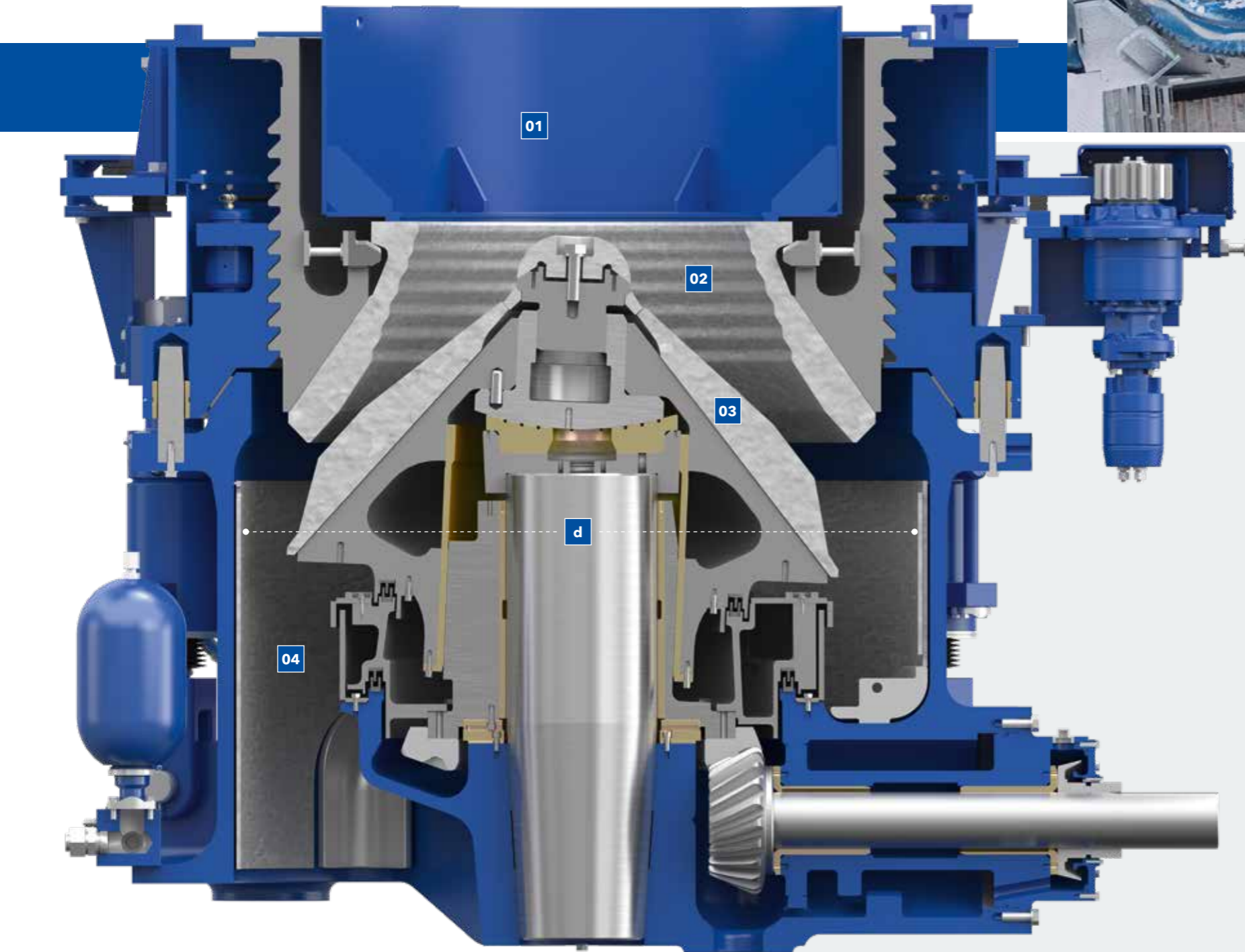

- 01** Cone crusher with large stroke
- 02** Bowl liner
- 03** Mantle
- 04** Main frame wear protection (see page 33)



TARGETED TO SUCCESS

For perfect crushing results.



Optimum crushing performance is always the result of the overall plant components being ideally matched to each other and the settings made by the operator.

Before implementing the project, it is important to understand the application in detail and to make important preparations. The KLEEMANN experts will be happy to support you!

Important basics

- > What do I want to achieve with my application? Define the objective of the application: output and/or quality
- > What exactly does my application look like? Take material samples and have them examined
- > Which machines are suitable for the application? KLEEMANN will support you with the AggFlow preparation

- > Which tools do I have to use? Info can be found in AggFlow
- > Is my personnel trained for using a cone crusher? KLEEMANN will train your personnel during commissioning
- > Have provisions been made for maintenance and spare part supply? Discuss this with your Service contact person

Areas of application of cone crushing plants

NATURAL STONE

Limestone / sandstone / greywacke / gravel / granite / gneiss / marble / quartzite / diabase / gabbro / basalt	Iron ore	Coal	Clay
--	----------	------	------

With these tips, you'll find the right settings to take on any task.

Well filled crushing chamber

- > Ensures throughput capacity as a higher crushing effect is generated in the crushing gap

Correct feed size

- > Has a strong influence on the crushing result, wear and the output of the cone crushing plant

Centric feeding of the feed material

- > Ensures a homogeneous distribution in the crushing chamber

Crushing ratio

- > The maximum crushing ratio (ratio of feed grain size / grain output) largely depends on the physical properties of the feed material.

This results in the following standard values:

CRUSHING RATIO				
Specification	Crushing stage	Compressive strength	Circuit	Reduction ratio
standard head	secondary	<300 MPa	open/closed	4:1
short head ¹	tertiary/quaternary	<300 MPa	open/closed	3.5-4.5:1
short head ²	tertiary/quaternary	<300 MPa	open/closed	2-3:1

¹ normal grain shape requirements

² high grain shape requirements

KLEEMANN > GOOD TO KNOW

In order to successfully implement a project with mobile cone crushers, it is important to understand the application and to collect all important information. This questionnaire will help you. Find out more at www.wirtgen-group.com/fragebogen-kleemann



For further information, scan the code



CONE CRUSHER CRUSHING TOOLS

For less wear and optimum results.



Cone crushers are mainly used when impact crushing is no longer possible due to the high compressive strength of the crushed material, or the wear costs due to the abrasiveness of the stone cannot be economically justified.

Due to their design, cone crushers are limited in terms of the feed size and the achievable reduction ratios. The plants are mainly used for recrushing in the secondary and tertiary crushing stages. Different CONE crushing tools are available.

USE OF THE CONE CRUSHER TOOLS

Application	Marking for identification	Max. feed size	Closed side setting in mm (CSS)	Cast alloy	Design
Secondary crushing stage > For final product > 25 mm > Reduction ratio* 3.5 to 5:1 > Open circuit > Large feed opening	Notch on one side	116 - 131	16 - 32	MnCr 18.2	S-CONE F.18
		138 - 157	19 - 38	MnCr 20.3	S-CONE F.20
		179 - 192	25 - 45	MnCr 18.2	S-CONE M.18
				MnCr 20.3	S-CONE M.20
				MnCr 18.2	S-CONE C.18
				MnCr 20.3	S-CONE C.20
Tertiary / quaternary crushing stage > For final product < 25 mm > Reduction ratio* 2.5 to 3:1 > Closed circuit > Long calibration zone	Notch on two sides	71 - 80	10 - 19	MnCr 18.2	SH-CONE F.18
				MnCr 20.3	SH-CONE F.20
		99 - 111	10 - 22	MnCr 18.2	SH-CONE M.18
				MnCr 20.3	SH-CONE M.20
		130 - 142	13 - 25	MnCr 18.2	SH-CONE C.18
				MnCr 20.3	SH-CONE C.20

APPLICATION-SPECIFIC WEAR PARTS

Crusher cone - versions

- > Standard
- > Short Head

Bowl liner - versions

- > Standard Fine
- > Standard Medium
- > Standard Coarse
- > Short Head Fine
- > Short Head Medium
- > Short Head Coarse

It all comes down to the right combination!

In order to receive a constant high material volume from a cone crusher with high final product quality, mobile cone crushers should be operated in the optimum range.

This begins with the selection and composition of the correct tool, which consists of cone and bowl liner.

Secondary crushing stage

- > Final product > 32 mm
- > Open circuit
- > Large feed opening

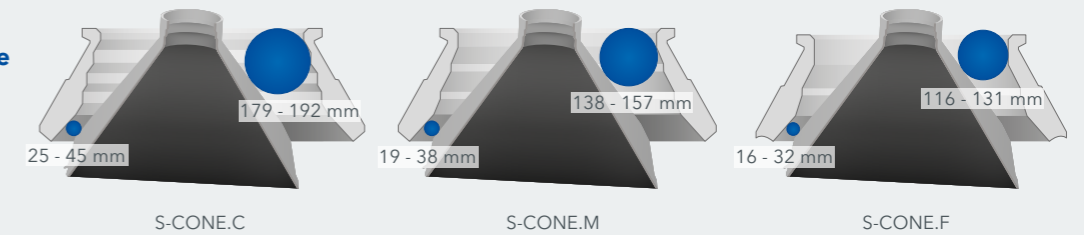

Tertiary crushing stage

- > Final product < 32 mm
- > Closed circuit
- > Long calibration zone

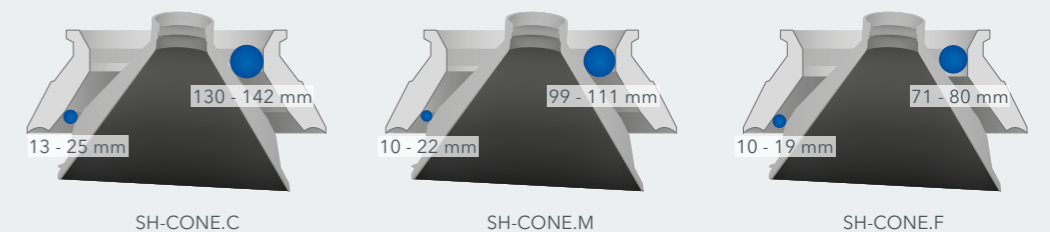

- > S-CONE stands for the Standard version
- > SH-CONE stands for the Short Head version



Crushing tools for cone crushers

WEAR LINING

For a longer machine service life and increased cost-effectiveness.



KLEEMANN Original
wear lining

Optimum protection of a wide range of crushing plant components extends the service life of the machine and increases cost-effectiveness.

Crushing plants are always subject to high forces and often especially high wear - particularly in certain zones or on components that come into heavy contact with the material to be processed. This wear is caused by pressure, impacts and friction. Various wear protection measures serve to protect these components and thereby enable a longer service life

of the equipment. However, they can also have an impact on performance. In crushing plants, the hopper unit and the pre-screen as well as the crushing unit are among the components that require special protection. Original KLEEMANN wear liners protect these components, ensure an optimal material flow and promote economic efficiency and sustainability.

Hopper unit and prescreen

On all mobile crushing and screening plants, the hopper unit is the first component that comes into contact with the feed material. This area is particularly exposed to high wear. To protect the hopper, therefore, different wear plates are available which, depending on the plant, are welded or bolted on.

The side walls of plants that have a prescreen (MOBIREX impact crusher, MOBICAT jaw crusher) are protected by wear plates.

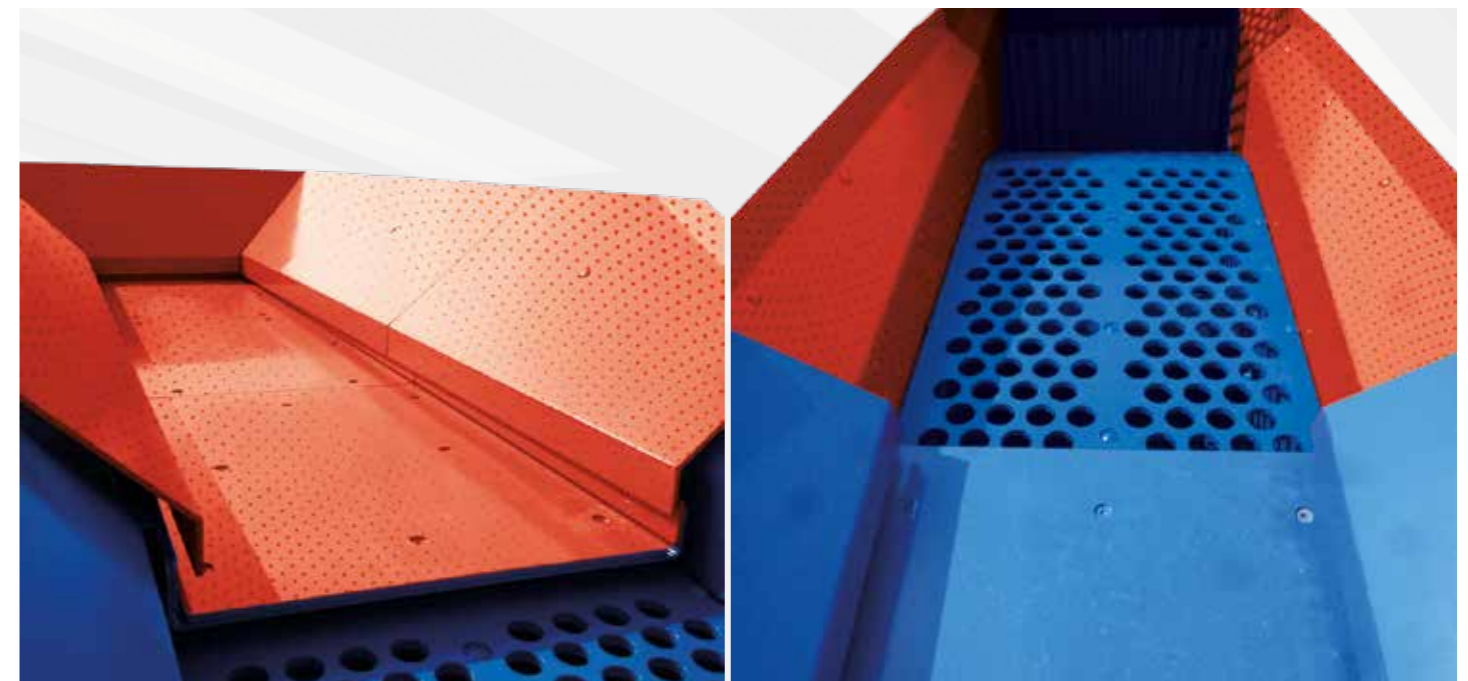

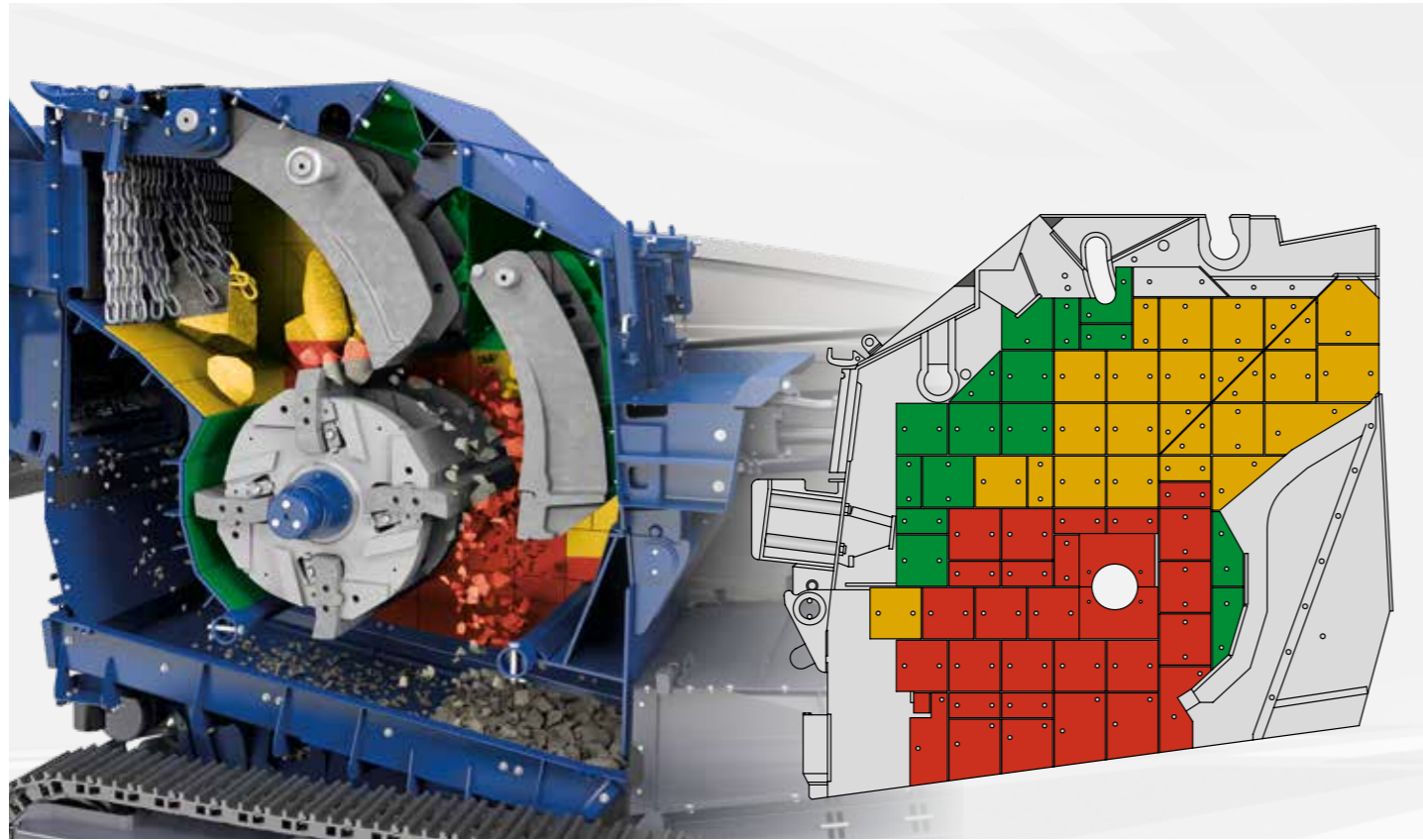

Impact crusher

To protect the crushing unit against damage, the MOBIREX impact crushers' housing is fully lined with highly wear-resistant plates. The crushing chamber can be divided into different wear zones. The area subject to the highest load is in the upper and discharge-side turning circle of the rotor

ledges. The wear plates are designed such that some of them can be replaced with wear plates from zones subject to less load. This considerably increases the overall level of utilization of the wear elements. The wear lining - suitable for the application - is available in three different quality levels.

QUALITIES AND APPLICATION RECOMMENDATION

Wear plates	Specification	Application
KRS.40	Hardness: up to 430 HV	KRS.40 with high impact resistance are recommended, in particular, for material with very low abrasiveness such as limestone or in the recycling of rubble and concrete.
KRS.50	Hardness: up to 530 HV	KRS.50 are recommended for stone with medium abrasiveness and recycling.
KRS.60	Hardness: up to 600 HV	KRS.60 are particularly suitable for materials with very high abrasiveness and with uncrushable elements (e.g. steel) in the feed material.
KRS.HW	Hardness: approx. 740 HV 10, approx. 62 HR (hardface welded)	KRS.HW are recommended in the event of highly abrasive wear. To protect the high-quality crusher housing against damage, it is completely panelled with highly wear-resistant plates. The wear and tear can vary considerably within the housing. In order to reduce the replacement times and wear costs, KLEEMANN offers special welded plates. Compared with KLEEMANN standard plates (hardness: 400 HV or 500 HV), these welded plates have a significantly longer service life.



Jaw crusher

The MOBICAT mobile jaw crushers have a fixed and an articulated crusher jaw, whereby the material is crushed by an elliptical movement sequence. Side wedges are installed on the sides of these opposing crusher jaws for protecting the crusher housing. The wedges have two parts; the lower part is subject to higher wear. This wear protection - matching the abrasiveness of the material - is available in three different quality levels (KRS.40, KRS.50, KRS.HW).



Cone crusher

Cone crushers crush the feed material in a circulating opening and closing crushing gap between bowl liner and crusher cone. To protect the MOBICONE plants' crusher housing, the main frame is equipped with wear protection. A counterweight wear guard and support arm guard are also provided.

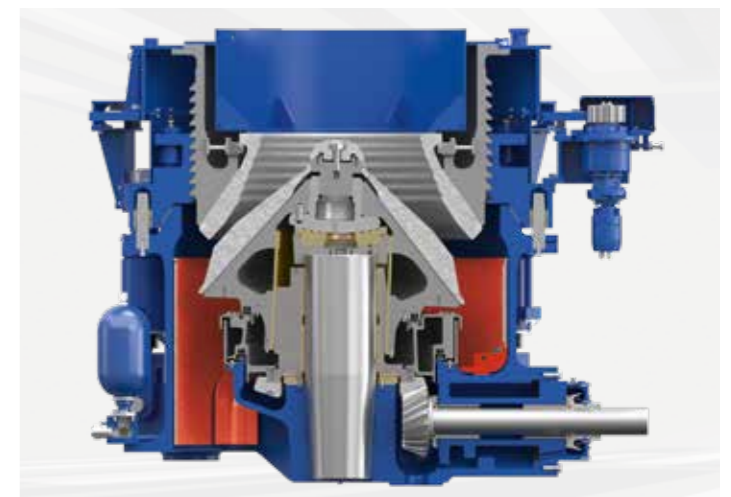

WIRTGEN GROUP ORIGINAL SPARE PARTS

Only the original parts will fulfil your expectations.

In the development of WIRTGEN GROUP original spare parts, we draw on decades of real-world experience from construction sites around the globe.

They are perfectly tailored to the requirements of our high-performance machines and enable them to deliver the efficiency and productivity you need. With WIRTGEN GROUP original spare parts, you can always be certain that you are doing the best for your fleet. Even short machine downtimes cost you time and money. Put your trust in what only genuine spare parts produced using state-of-the-art manufacturing processes can offer you - top quality for maximum reliability and a long service life.

Prompt delivery

Our local service specialists provide in-depth advice during the purchasing process and ensure that your order is processed smoothly and quickly. Thanks to our well-stocked worldwide spare parts warehouses and our sophisticated logistics system, we will immediately and reliably deliver the genuine part or parts you need anywhere in the world, even in the event of longer import times. The reliable WIRTGEN GROUP spare parts service will even reach you at the most remote construction sites. WIRTGEN GROUP original spare parts - maximum reliability, long service life and rapid availability.

Your benefits

- > Highest quality: For a long machine life
- > Ideal availability: Rapid delivery thanks to high storage capacities and the very latest logistics
- > Expert advice: Service specialists with sound technical knowledge
- > First-class support: Fast, reliable order processing
- > Ideally sorted: Extensive, thematically coordinated service and maintenance packages



WIRTGEN GROUP



KLEEMANN GmbH

Manfred-Wörner-Str. 160
73037 Göppingen
Germany

T: +49 7161 206-0

M: customersupport@kleemann.info

▶ www.kleemann.info